

# PBM-0624

## PIPE BENDING MACHINE

Robust and safe for the operator  
Wide bending range  
PTO available for mandrel feeding  
Equipped with winch for Pipe Handling  
Polyurethane lined bending sets available



EUROPIPELINEGROUP  
  
PIPELINE SOLUTIONS

# BASIC MACHINE DATA

## ENGINE

Model	Yanmar 4tnv88
Net Flywheel power	35.4 kW
Governed speed	2300 rpm
Displacement	2.2L - 4 in line cylinder
Total Battery Capacity	100Ah

## REFILL CAPACITIES

Fuel tank	100L
Hydraulic oil tanks	125L

## HYDRAULIC SYSTEM

Pump type	Gear pump
Pump pressure max	250 bar
Maximum oil flow	100 liters/min



### Hydraulic or pneumatic mandrels

In addition to the full range of pipe bending machines, EPE offers pipe bending hydraulic mandrels to optimize bending operation in case of light wall thicknesses, avoiding buckling of the pipe.

We offer manual (up to 14") or hydraulic mandrels with up to two motors in a wide range of sizes which can be easily fed through the dedicated PTO outlet of the bending machine.

## HYDRAULIC CYLINDERS

Outboard cylinder	2x 200mm x 350mm
Inboard cylinder	2x 200mm x 180mm
Wedge cylinder	1x 150mm x 650mm
Clamp cylinder	1x 80mm x 400mm

## FRAME

High resistance carbon steel S355JR

## WINCH

Type	hydraulic worm gear winch
Maximum operating pressure	150 bar
Maximum feed flow rate	40 lt/min
Rated pull 1st layer	4500 kg
Rope length	40 m
Rope diameter	12 mm
Maximum Speed 1st layer	7,1 mt/min

## AUXILIARIES

Hydraulic PTO for mandrel	quick coupling 1/2"
---------------------------	---------------------

### Bending sets

EPE bending sets are manufactured with high quality steel, welded and reinforced in high stress areas for maximum strength and resistance. The internal surface is finished with tooling machines to guarantee the required accuracy and can also be proposed with Polyurethane lining upon request. Bending sets are compatible with bending machines by other manufacturer.

### Pipe rollers

Pipe drive rollers complete of ball bearings rollers easy the handling of the pipe

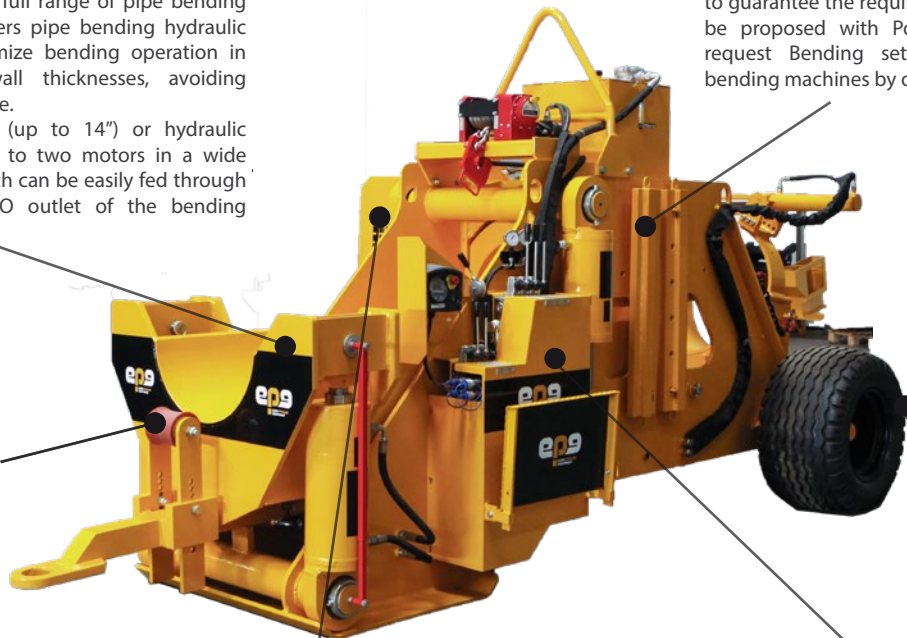

### Wheels

Small bending machines are mounted on wheels for easy touring and limited maintenance.

### ENGINE

Caterpillar or Yanmar diesel engines are selected as the best fitting solution according to the size of the equipment all of them including integrated filtration system, and self-stretching fan towing seals. All comply with the environmental regulations in terms of emissions and noise.



### OPERATOR'S PLATFORM

The position of the control platform makes EPE bending machine unique in terms of operating comfort and guarantees maximum visibility and low noise levels to the operator.

# BENDING DATA

Maximum tickness bended in function of steel type - All data are expressed for *inch/mm*

Pipe Size	X52	X60	X65	X70	Radius	Max.Degree*
6/168	2/50.80	2/50.80	2/50.80	2/50.80	3.95	135
8/219	2/50.80	2/50.80	2/50.80	2/50.80	4.6	115
10/273	2/50.80	2/50.80	2/50.80	2/50.80	6.1	85
12/324	2/50.80	2/50.80	2/50.80	2/50.80	7.6	70
14/356	2/50.80	2/50.80	2/50.80	2/50.80	10.35	50
16/406	2/50.80	3.19/81	2.66/67.5	2.66/67.5	11.6	45
18/457	2.38/60.5	1.89/48	1.69/43	1.69/43	15.85	33
20/508	1.65/42	1.38/35	1.24/31.5	1.24/31.5	19.5	27
22/559	1.26/32	1.06/27	0.96/24.5	0.96/24.5	24	22
24/610	1.02/26	0.87/22	0.79/20	0.79/20	29.5	20

\* per 12 meter pipe



## OPTIONS

- **Bend Angle Measurement Device:** a wireless tool made of three components: two of them placed at both pipe ends and the remote control is hold by the operator. Working temperature -40°C to 50°C. Device precision 1/50 grades.
- **Integrated Closed Cabin:** Upon request the bending machine can be equipped with a heated/conditioned cabin for operator.
- **Artic Version:** Equipped with webasto and dedicated components to operate in the range -40°C/+40°C.

# DIMENSIONS AND WEIGHTS

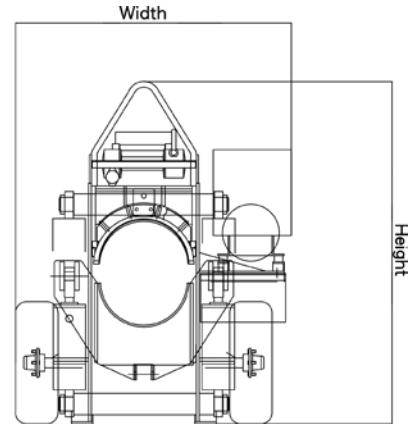
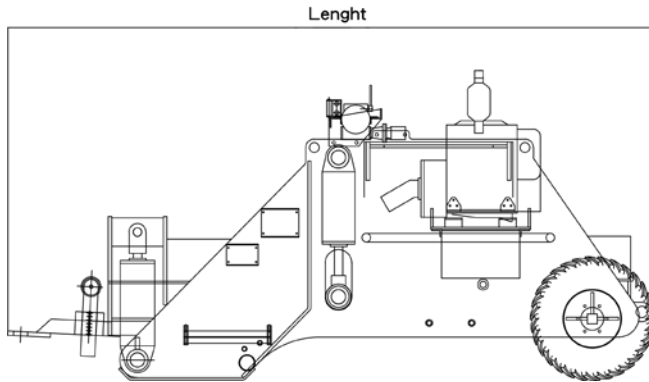

## DIMENSIONS

Overall lenght	4700 mm
Width	2100 mm
Height over exhaust	2700 mm

## SHIPPING DIMENSIONS

Overall lenght	4700 mm
Width	2100 mm
Height over exhaust	2300 mm

## WEIGHTS

Operating weight	7500 kg	16534 lbs
------------------	---------	-----------



EUROPIPELINEGROUP



**EURO PIPELINE EQUIPMENT SPA**  
 Strada Provinciale 6 bis  
 Località Cascine Draghi  
 29013 Carpaneto Piacentino (PC)  
 ITALY

**Registered Office**  
 via Pontaccio 8  
 20121 Milan  
 ITALY

[info@europipeline-equipment.com](mailto:info@europipeline-equipment.com)

[www.europipeline-equipment.com](http://www.europipeline-equipment.com)