

BASIC MACHINE DATA

ENGINE

Model	CAT® C7.1*
Net Flywheel power	228 HP/168 kW
Governed speed	2200 rpm
Displacement	6 in line cylinder

*optional engines: IVECO N67, PERKINS 1106D

TRANSMISSION

Type	Hydrostatic closed circuit
Brakes	2 integrated negative control
Final drives	Epicycloidal oil soaked
Maximum speed (empty)	1 speed - 5 km/h (4 km/h*) 2 speed - 9 km/h (7,5 km/h*)

*value with rubber tracks

CONTROLS

Type	Twin Axis Joystick
------	--------------------

PERFORMANCE

Max Slope 1 speed (empty)	36° / 80%
Max Slope 2 speed (empty)	18° / 40%
Departure Angle	20°
Approach Angle	26°

FLUID CAPACITIES

Fuel tank	125 lt
Hydraulic System circuit	133 lt
Cooling system	20 lt
Engine oil	16 lt
Final drive each	3,5+3,5 lt

HYDRAULIC SYSTEM

Main Pumps	2 Sauer Danfoss variable speed
Maximum capacity	165 lt/min
Maximum operating pressure	400 bar
Service pumps	1 mechanical pump
Maximum capacity	83 lt/min

TRACK FRAME

Material	S355 (eq A572 gr.50)
Platform Surface	7,1 sqm
Number of bottom rollers	8
Number of carrying rollers	2
Lenght of track on the ground	3030 mm
Standard shoes width	600 mm
Ground contact area	3,63 sqm

*value with steel tracks

ELECTRIC SYSTEM

Operating voltage	24 V
Maintenance free supplied batteries	2x12 V
Total Battery Capacity	2x135 Ah
CCA	800 A
Alternator	85 A



TP15 DUMPER FOR INERT AND SCRAPS TRANSPORT

The TP-15 is also available in dumper arrangement suitable for material handling. The dumper is made by hard steel construction with a maximum payload of 6.7 tons, a loading capacity struck of 2,7 cm and a dumping angle of 72° to ensure excellent loading, transport and discharge of the materials.

The dumper cylinder controls are integrated in the cabin cockpit and proper lighting of the charge and discharge point are foreseen.

Our TP-15 is the perfect tractor for pipeline welding and not only. It has been designed in compliance with the most common requirements of pipeline contractors: it is very light, flexible and with excellent stability and traction.

The TP-15 is designed to be easily maintained at site: all its components such as transmission, engine, cranes, hydraulics etc.. have been selected from top suppliers with a global assistance network. In particular the TP-15 is powered by CAT® engines, the best solution for high reliability and best after sales service with the back up of the world leading manufacturer in the construction sector. Alternative engine manufacturer are available as an option.

Special care has been dedicated to the comfort of the driver:

- the engine is sound proof
- the cabin is mounted on shock absorbers for best comfort
- Upon request front blade, A/C, Webasto, GPS and rear camera can be installed

Also safety has been taken into account and all the TP-15 adopt ROPS protection for the operator cabin.

To give the maximum flexibility and value-for-money at site, the TP-15 can be easily customized and used for many different purpose.



TP-15 DUMPER

Robust and multipurpose vehicle
Easy platform dismantling
Caterpillar Engine
Steel or rubber chain
Sauer-Danfoss hydrostatic transmission



EUROPIPELINEGROUP
PIPELINE SOLUTIONS

DIMENSIONS AND WEIGHTS

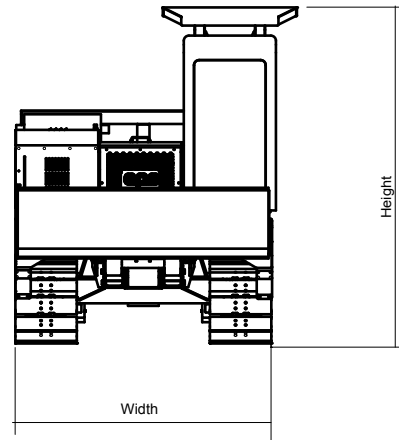
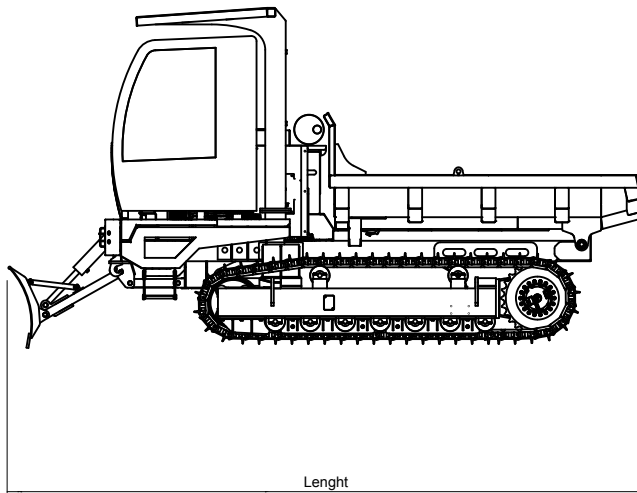

DIMENSIONS

Width	2750 mm
Lenght	6520 mm
Height	3320 mm

NET WEIGHT 9.000 KG

OPERATIONAL WEIGHT 15.000 KG



EUROPIPELINEGROUP



Località Cascine Draghi
29013 Carpaneto Piacentino (PC)
ITALY

Registered Office
via Pontaccio 8
20121 Milan
ITALY

info@europipeline-equipment.com

www.europipeline-equipment.com